

**SHARP** understands that today's office environment requires a reliable, affordable and efficient system which can cope with a wide range of individual needs/**This is Why** our MX-B382 has been designed from the ground up to deliver superior every-day performance with exceptional flexibility.

# MX-B382 Digital Multi-Function System





Energy Star  
Compliant



7.0" Colour  
LCD Panel

# **/This is Why** our MX-B382 MFP is the ideal candidate for the modern workplace

## **Superior design for modern workgroups**

Powerful and versatile, yet surprisingly compact the new MX-B382 has everything you need to create, copy and manage documents in the workplace.

Designed to deliver its best quality even at its top speed of 38 ppm, the MX-B382 meets all the demands of the modern office. Fast, high quality black & white printing and copying, network colour scanning, powerful security and a range of finishing options: they all come together in a robust A4 MFP for everyday use.

What's more, we've placed a special emphasis on ease of use and productivity.

It comes with a 7.0 inch colour touch screen control panel, for example, which not only has thumbnail previews for intuitive control but can also be customised with different colours and shortcut keys. In addition, the MX-B382 can run Sharp OSA® (Open Systems Architecture) applications to automate the capture and distribution of documents, as well as other manual tasks.

## **Advanced energy-saving technology**

The Energy Star certified MX-B382 is designed to fully support your environmental objectives. We've reduced the warm up time to less than 50 seconds and limited power consumption in standby mode to less than 1 Watt. That's just enough to receive a fax.

The result is a versatile A4 MFP – ideal for everyday use – that has an impressively low Typical Electrical Consumption of just 5.72 kWh for an average week.

## **Optimum efficiency**

Many MFPs are fast – some of the time. But the MX-B382 is fast all of the time. In fact, it can race along at 38 pages per minute even at its maximum (1,200 x 1,200 dpi) image quality.

But there's a lot more to the MX-B382 than impressive output speeds. The high speed scanner can process as many as 33 originals per minute (in colour as well as in black & white), the paper supply can be expanded right the way up to 2,100 sheets simply by adding extra paper drawers, plus there's a wide range of useful productivity features included at no extra cost.





**Convenient  
Thumbnail  
Views**



**Superior  
Print  
Quality**

# **/This is Why** choosing a Sharp MFP will help boost your productivity and efficiency

## **Maximum productivity**

The new MX-B382 builds on the success of Sharp's other office MFPs by incorporating some of our very latest productivity-enhancing technologies. Take scanning, for instance.

The MX-B382's advanced scanning capabilities let you capture and distribute information throughout your business, unlocking its true (but often hard to share) value.

You can scan documents directly to your desktop, a folder on your network or FTP server, or simply a USB memory stick. It's also easy to scan to multiple email addresses: just browse the address book, select, and send.

Documents can be scanned into your choice of TIFF, PDF, encrypted PDF, JPEG or XPS formats and, if you send a copy to your PC, you can use Sharpdesk document management software. Sharpdesk lets you store and manage files of virtually any format, and effortlessly combine them into new multipage documents.

## **Convenient filing**

The MX-B382 comes with an 80 GB hard drive on which you can store jobs (neatly indexed with thumbnail views) for later reuse. Choose from Quick Filing for temporary storage, Advanced Filing for long-term archiving, or a Main Folder for convenient workgroup sharing. You can also store your documents in private, password protected folders.

## **Impressive image quality**

Print, copy or scan – everyone in the office will enjoy excellent quality from the MX-B382; job after job, day after day.

The specially formulated developer and toner deliver enhanced image quality across a useful range of media, at a print resolution of 1,200 x 1,200 dpi for the consistently accurate reproduction of faint lines and fine details.

With Sharp, there's no fuss and no special features to learn: just easy, convenient quality that can be mastered in moments.

## **Extra value features**

We've taken some of the most successful features of our departmental A3 machines and included them on the MX-B382 as standard. It has two USB ports, for example, for easy walkup printing (and for capturing scans) without the need for a PC, and you can even print directly from popular file formats such as XPS, PDF, TIFF and JPEG without using a printer driver.

A fast, 50-sheet Reversing Single Pass Feeder makes two-sided copying quick and efficient, the first copy out time is just 8.0 seconds\*, it comes with Job Build for managing high volume copying and there's an 80 GB hard drive for storing jobs and electronically sorting them.

It all adds up to a versatile, highly productive MFP which still manages to be one of the most compact in its class.

\* Best achieved time based on A4 sheets, feeding from first paper drawer, using document glass, when machine is ready. May vary depending on machine condition and operating environment.



# **/This is Why** our products offer superior security, convenience and flexibility

## **An investment for the future**

The MX-B382 will keep up with the needs of your team as you take on new challenges.

Extra security with encryption and file erasure is available, and there's an optional space-saving Inner Finisher which sorts, staples and offset stacks – all without taking up any extra office space.

Fax users will appreciate the Super G3 and Internet fax options, with thumbnail views and Inbound Routing for making sure that faxes go straight to the intended destination and can be printed or not as the recipient chooses.

The MX-B382 can run the latest Sharp OSA (Open Systems Architecture) applications, transforming it into an integrated gateway to your networked business applications. Different applications can be used for automating manual office tasks, such as capturing and distributing documents, or to let you access network applications and data

## **Multi-level security**

Even the most basic configuration of the MX-B382 comes with multi-layered security that works 24/7 to keep your network and data safe from all unauthorised access, whether intentional or innocent.

Standard security measures include Password-controlled User Authentication, a secure network interface, SSL to prevent network data from being intercepted, IEEE 802.1X compliance, IPsec compatibility and password protected encrypted PDFs. But that's not all. The MX-B382 has advanced security functions that provide multiple levels of network and data security.

For even greater security, choose the optional Data Security Kit, which encrypts and securely erases data from the hard disk and internal memory, at specified intervals or on demand. The kit also has a Document Control facility to prevent unauthorised printing, copying, scanning, faxing and filing, limiting the potential for information to be stolen.

## **Easy to manage**

Although the MX-B382 is both powerful and versatile, it's remarkably easy to manage. A glance at the Job Status Screen on the control panel, for example, will show you all copy and print jobs and their position in the queue. But that's just one innovation. We've also made life easier with:

**Sharp Remote Device Manager** – Installed on your file server, Sharp Remote Device Manager gives you complete, real-time control of your printers and MFPs through any standard web browser. Error-reporting, technical support, driver installation, firmware upgrades, printer configuration: everything is easier and more accessible.

**Web Page Management** – Every important setting can be managed through a standard web browser, including user access, security and other controls and configurations, without leaving your desk.

**Printer Status Monitor** – Lets you check the MFP's operating status from your PC, so you can make sure there's sufficient toner and paper before you start a job. What's more, as soon as your documents are printed an alert appears on your desktop, saving wasted trips across the office.

**Remote Diagnosis** – Solve issues before they become problems by monitoring your MFPs via your web browser, and receive timely email alerts when maintenance is required.

**Remote Access Interface** – Lets you duplicate and operate the MX-B382's main control panel on your PC, letting you control every major function from your desktop.



Space-Saving  
Inner Finisher

# MX-B382 – options

## Finishing

### 1. MX-FN12 Finisher

- A4 - A5, offset/staple
- Paper capacity: 280 sheets (A4, 80 g/m<sup>2</sup>)
- Stapling capacity: max. 30 sheets
- Staple position: 1 location (corner)

## Base Unit

### 2. MX-CSX1 Paper Drawer

- A4 - A5, 500 sheets (80 g/m<sup>2</sup>)  
(must be the first paper drawer)

### 3. MX-CSX2 Paper Drawer

- A4 - B5, 500 sheets (80 g/m<sup>2</sup>)

### 4. MX-DS14 Stackable Cabinet

- Stackable cabinet for MFP height adjustment

### 5. MX-DS13 Base Plate

- Attaches to base of drawer/cabinet configuration

## Faxing

### 6. MX-FXX3 Fax Expansion Kit

- Super G3 fax module

### MX-FWX1 Internet Fax Expansion Kit

- Enables faxes to be sent/received over the Internet

## Printing

- **MX-PUX1 XPS Expansion Kit: requires L80MXSMX3**  
(enables XPS printing)
- **L80MXSMX3 Expansion Memory Board**  
(1 GB additional memory)
- **AR-PF1 Barcode Font Kit**  
(enables barcode printing)

## Sharpdesk™ Licenses

- **MX-USX1** Sharpdesk 1-License Kit
- **MX-USX5** Sharpdesk 5-License Kit
- **MX-US10** Sharpdesk 10-License Kit
- **MX-US50** Sharpdesk 50-License Kit
- **MX-USA0** Sharpdesk 100-License Kit

## Sharp OSA®

- **MX-AMX1** Application Integration Module  
(adds data to scanned documents before processing or archiving)
- **MX-AMX2** Application Communication Module  
(create, configure and execute scanning and printing jobs)
- **MX-AMX3** External Account Module  
(authenticate, track and restrict usage by individual/workgroup)

## Security

- **MX-FR26U** Data Security Kit  
(encrypts and erases data on the hard disk drive)

Some options may not be available in some areas.

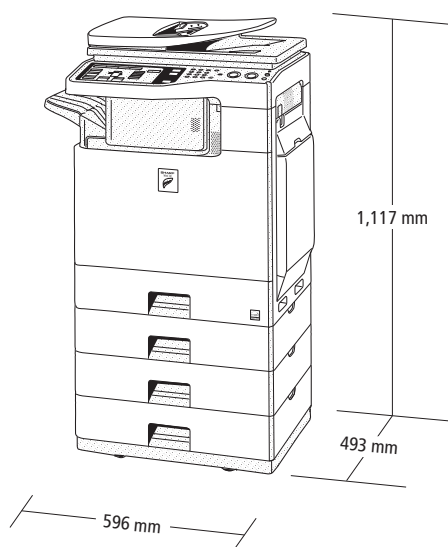



Multiple  
**Configuration**  
Options



**Superb**  
Versatility

# MX-B382 – options

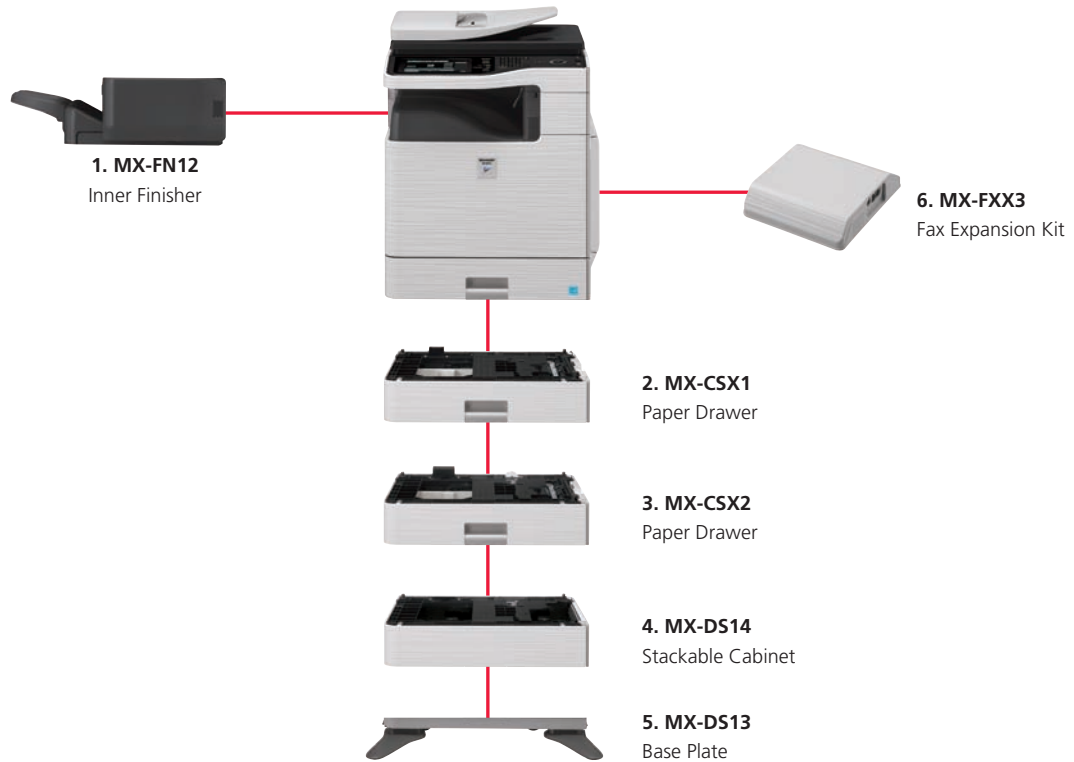

## Configuration examples



**Base Unit**  
3 x Stackable Cabinets  
Base Plate



**Base Unit**  
Paper Drawer  
2 x Stackable Cabinets  
Base Plate



**Base Unit**  
Finisher  
2 x Paper Drawers  
Stackable Cabinet  
Base Plate



**Base Unit**  
Finisher  
3 x Paper Drawers  
Base Plate



# Specifications

## MX-B382 Digital Multi-Function System



### General

Engine speed (max)	A4: 38 ppm/cpm	
Paper size	A4R (max)	A5R (min)
Paper weight	Drawer:	60 - 105 g/m <sup>2</sup>
	Bypass:	55 - 209 g/m <sup>2</sup>
Paper capacity	Std:	600 sheets (1 x 500-sheet drawer and 100-sheet multi-bypass tray)
	Max:	2,100 sheets (4 x 500-sheet drawers and 100-sheet multi-bypass tray)
Warm-up time* <sup>1</sup>	Less than 50 sec.	
Memory	Copier:	512 MB (std)
	Printer:	512 MB (std) 1.5GB (max)
HDD capacity* <sup>2</sup>	80GB	
Power requirements	Rated local AC voltage $\pm 10\%$ , 50/60 Hz	
Power consumption (max)	1.84 kW (220 - 240V)	
Dimensions (wdh)	560 x 493 x 714 mm	
Weight	Approx. 44 kg	

### Copier

Original paper size	Max:	A4
First copy time* <sup>3</sup>	8.0 sec.	
Continuous copy	Max:	999 copies
Resolution	600 x 600 dpi	
Gradation	Equivalent to 256 levels	
Zoom range	50 to 200% in 1% increments	
Preset copy ratios	8 ratios (4R/4E)	

### Colour Network Scanner

Scan method	Push scan (via operation panel), Pull scan (with TWAIN-supporting application)	
Scan resolution:	Push:	100, 200, 300, 400, 600 dpi
	Pull:	75, 100, 150, 200, 300, 400, 600 dpi, 50 to 9600 dpi, custom
File formats	TIFF, PDF, Encrypted PDF, JPEG (colour only), XPS* <sup>4</sup>	
Scanner utilities	Sharpdesk™	
Scan destinations	Scan to e-mail, desktop, FTP server, network folder, USB memory	

### Document Filing

Document filing capacity	Main and custom folders* <sup>5</sup> : 38GB, 5,500 pages* <sup>5</sup> or 3,000 files Quick file folder: 12GB, 1,700 pages* <sup>5</sup> or 1,000 files
Stored jobs	Copy, print, scan, fax transmission* <sup>6</sup>
Storage folders	Quick file folder, main folder, custom folder (max. 1,000 folders)
Confidential storage	Password protection

### Network Printer

Resolution	1,200 x 1,200 dpi
Interface	USB 2.0 10Base-T/100Base-TX/1000Base-T
Supported OS	Standard: Windows® 2000, Windows® XP, Windows® Server 2003/2008/2008R2, Windows® Vista, Windows® 7 Optional: Mac OS 9.0 - 9.2.2, Mac OS X 10.2.8, 10.3.9, 10.4.11, 10.5 - 10.5.8, 10.6 - 10.6.2
Network protocols	TCP/IP (IPv4, IPv6), IPX/SPX (NetWare), NetBEUI, EtherTalk (AppleTalk)
Printing protocols	LPR, Raw TCP (port 9100), POP3 (e-mail printing), HTTP, Novell Printserver application with NDS and Bindery, FTP for downloading print files, EtherTalk printing, IPP option: XPS* <sup>7</sup>
PDL emulation	Standard: PCL5e/PCL6 emulation, PS3 emulation Option: XPS* <sup>7</sup>
Available fonts	80 fonts for PCL, 136 fonts for PS3 emulation
<b>B/W Facsimile (optional MX-FXX3 required)</b>	
Compression method	MH/MR/MMR/JBIG
Communication protocol	Super G3
Transmission time	Less than 3 seconds* <sup>8</sup>
Modem speed	33,600 bps - 2,400 bps with automatic fallback
Transmission resolution	Standard: 203.2 x 97.8 dpi Extra Fine: 406.4 x 391 dpi
Recording width	A4 - A5
Memory	8 MB flash memory
Grey scale levels	Equivalent to 256 levels

\*<sup>1</sup> At rated voltage. May vary depending on machine conditions and operating environment.

\*<sup>2</sup> 1 GB = One billion bytes when referring to hard drive capacity. Actual formatted capacity is less.

\*<sup>3</sup> Best achieved time based on A4 sheets, feeding from 1st paper drawer, using document glass, when machine is ready. May vary depending on machine's condition and operating environment.

\*<sup>4</sup> To view XPS files on PCs not running Windows Vista, you must have the XPS Viewer application installed.

\*<sup>5</sup> Measured using Sharp's standard chart (A4 with 6% coverage, B/W). The Quick File Folder shares the HDD with the Job Build function; up to 12 GB of data storage is available when using both functions. The storage capacity will be less for colour pages.

\*<sup>6</sup> Optional MX-FXX3 required.

\*<sup>7</sup> Optional MX-PUX1 & MX-SMX3 required.

\*<sup>8</sup> Based on Sharp's standard chart with approx. 700 characters (A4 portrait) at standard resolution in Super G3 mode, 33,600 bps, JBIG compression.



**MX-B382**

Digital Multi-Function System



**SHARP**  
**/This is Why**

Sharp Electronics (UK) Ltd  
4 Furzeground Way, Stockley Park,  
Uxbridge, Middlesex, UB11 1EZ  
Tel: 020 8734 2000 Fax: 020 8734 2400  
Website: [www.sharp.co.uk](http://www.sharp.co.uk)